

EN

LRH 200

LRH 3002.07
www.liebherr.com

LIEBHERR

Piling and drilling rigs



Concept and characteristics

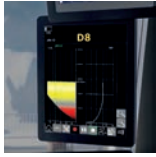

PDE[®]
Process Data Recording

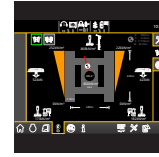

Ground
Pressure
Visualization



MyJobsite



Radio remote
control



LIPOS[®]
Positioning System



LiDAT[®]
Data Transmission

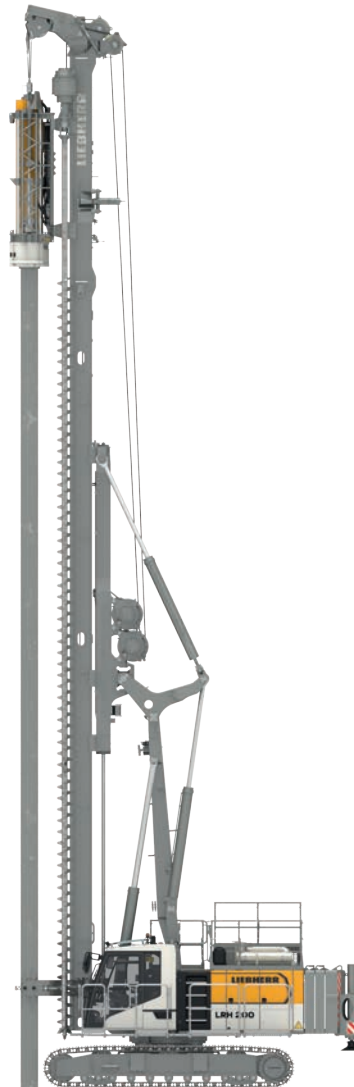

The robust universal machine for a wide variety of applications

- Hydraulic hammer
- Pre-drill
- Continuous flight auger drilling
- Full displacement drilling
- Soil mixing
- Down-the-hole drilling

Assistance systems

- Cruise Control for all main functions
- Joystick control for all machine functions
- Ground Pressure Visualization
- Radio remote control
- Leader inclination memory
- Positioning system
- Drilling assistant
- Free-fall winches with slack rope monitoring and prevention

Technical description



Diesel engine

Power rating according to ISO 9249	250 kW (335 hp) at 1700 rpm
Engine type	Liebherr D 936 A7-04
Fuel tank capacity	700 l with continuous level indicator and reserve warning
Exhaust certification	EU 2016/1628 Stage V; EPA/CARB Tier 4f ECE-R.96 Power Band H non-certified emission standard



Hydraulic system

Pump for working tools	2x 272 l/min
Separate pump for kinematics	130 l/min
Hydraulic oil tank capacity	600 l
Max. working pressure	350 bar
Hydraulic oil	electronic monitoring of all filters use of synthetic environmentally friendly oil possible



Crawlers

Drive system	with fixed axial piston hydraulic motors
Crawler side frames	maintenance-free, with hydraulic chain tensioning device
Brake	hydraulically released, spring-loaded multi-disc holding brake
Drive speed	0-1.3 km/h
Track force	665 kN
Grousers	width 900 mm (option 700 and 800 mm)



Swing gear

Drive system	with fixed axial piston hydraulic motors, planetary gearbox, pinion
Swing ring	triple-row roller bearing with external teeth
Brake	hydraulically released, spring-loaded multi-disc holding brake
Swing speed	0-3.75 rpm continuously variable



Hammer winch with free fall

Line pull (effective)	200 kN
Line pull in pile driving operation	180 kN
Rope diameter	24 mm
Rope speed	0-56 m/min

The winch is outstanding in its compact design and easy assembly. Clutch and braking functions on the free-fall system are provided by a compact designed, low wear and maintenance-free multi-disc service brake.



Pile winch with free fall

Line pull (effective)	200 kN
Line pull in pile driving operation	160 kN
Rope diameter	24 mm
Rope speed	0-56 m/min

The winch is outstanding in its compact design and easy assembly. Clutch and braking functions on the free-fall system are provided by a compact designed, low wear and maintenance-free multi-disc service brake.

Remarks:

- Illustrations showing the types of application (e.g. full displacement drilling, continuous flight auger drilling etc.) are examples only.
- Weights and transport dimensions can vary with the final configuration of the machine. The figures in this brochure may include options which are not within the standard scope of supply of the machine.

Dimensions

Standard

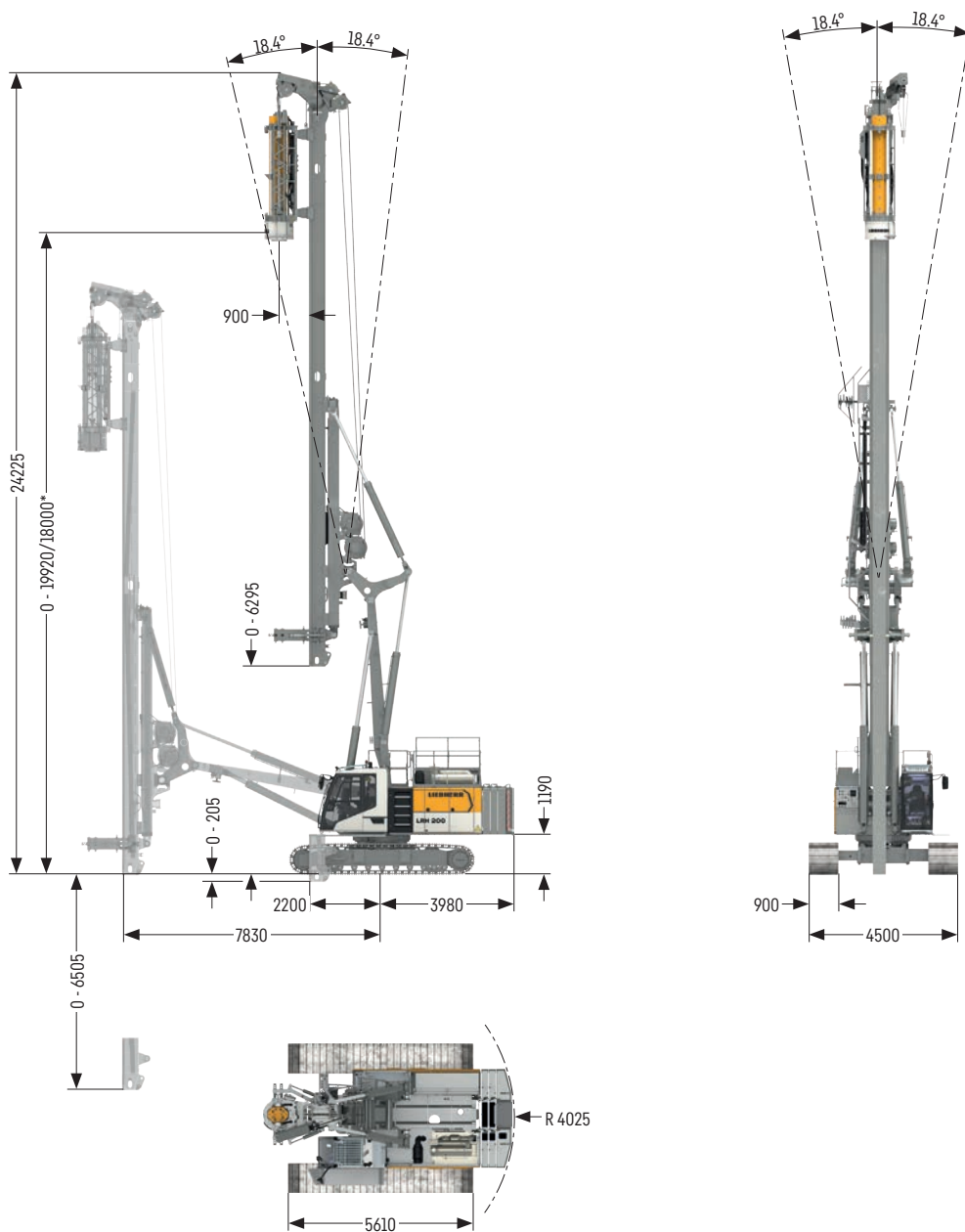

Operating weight

Total weight with hammer H 6-6	t 81.0
Total weight with hammer H 10-100	t 87.5

The operating weight includes the basic machine LRH 200 and 18 t counterweight.

* Hammer H 10-100

Folding leader

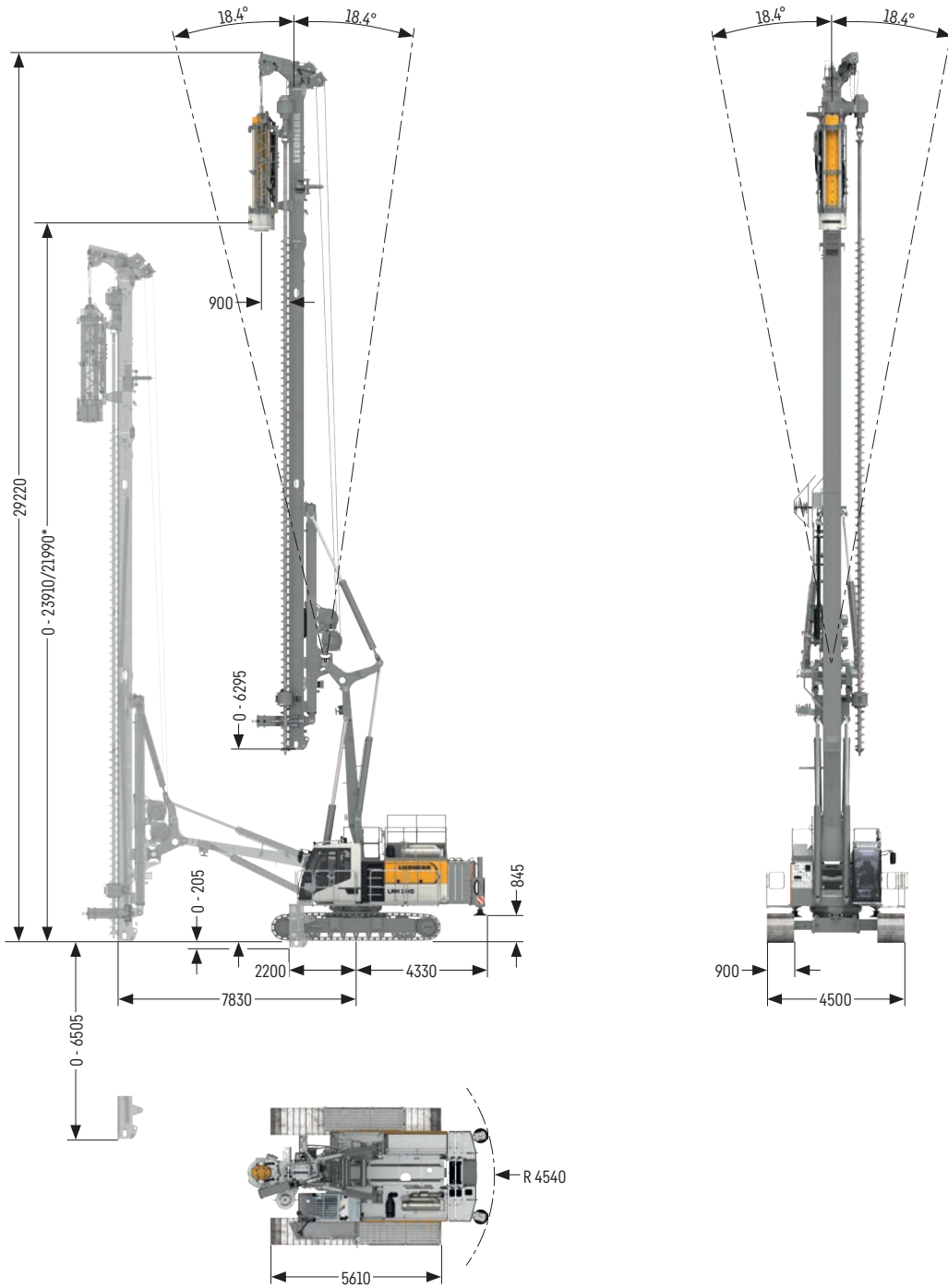

Operating weight

Total weight with hammer H 6-6	t 84.4
Total weight with hammer H 10-100	t 90.9

The operating weight includes the basic machine LRH 200, rotary BA 35 and 18 t counterweight.
 * Hammer H 10-100

Drilling version

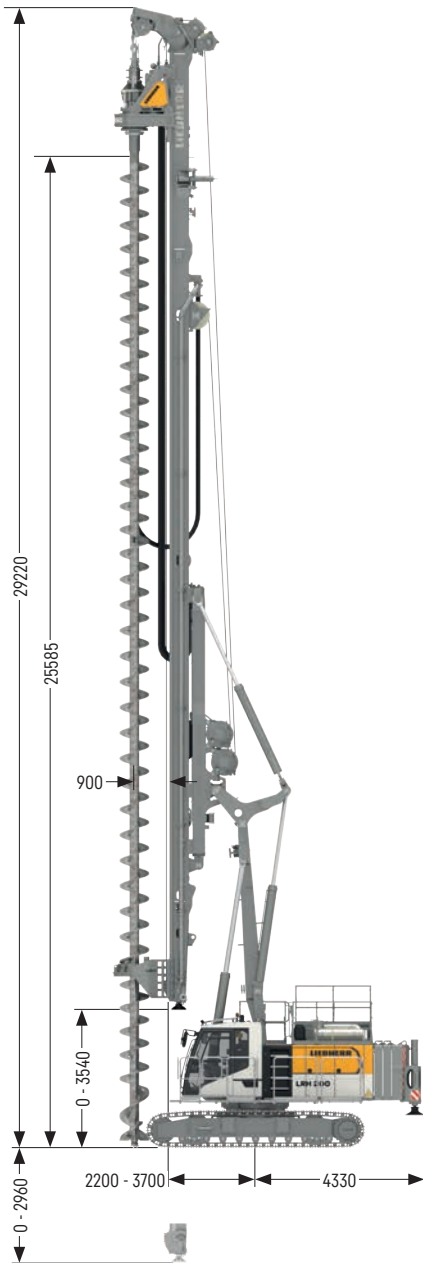

Operating weight

Total weight with 900 mm 3-web grousers t 90.4

The operating weight includes the basic machine LRH 200 incl. rotary BAT 250, auger, auger cleaner and 18 t counterweight.

Inclinations for pile driving operation

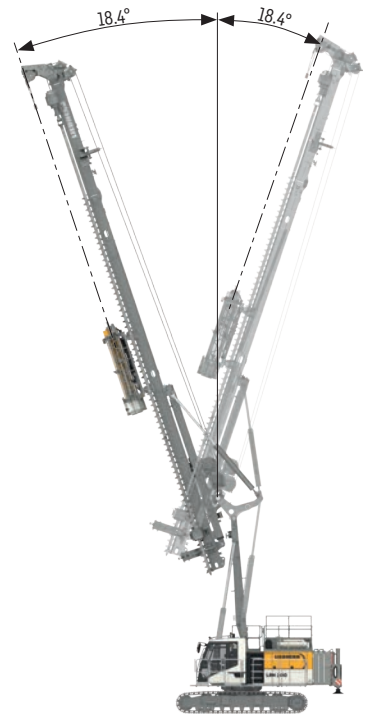

Transport dimensions and weights

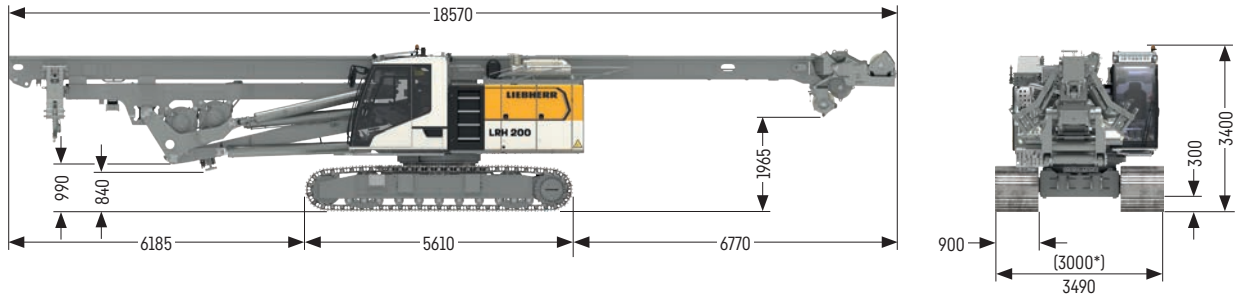

Transport standard

includes the basic machine (fully tanked and ready for operation) with leader, without counterweight t 53.3

* with 700 mm grousers, without all round platform and railings

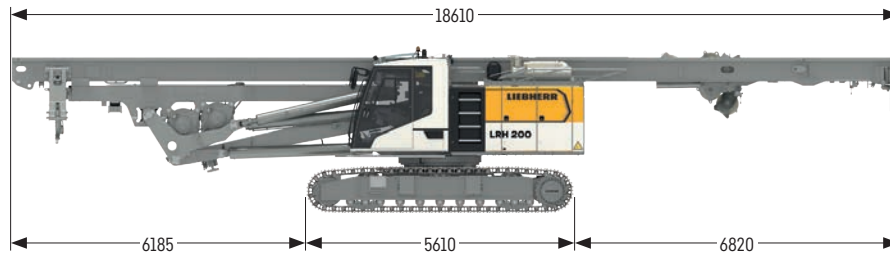

Transport folding leader

includes the basic machine (fully tanked and ready for operation) with leader, without counterweight t 54.9

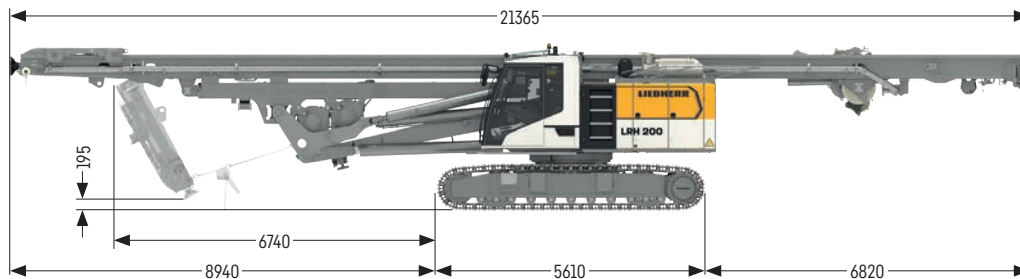

Transport drilling version

includes the basic machine (fully tanked and ready for operation) with leader, concrete supply line and multi-sledge, without counterweight t 57.0

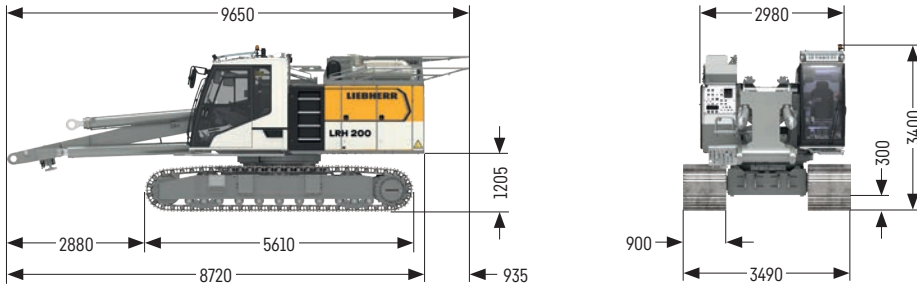

Basic machine

with crawler side frames, without counterweight	t 35.7
---	--------

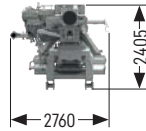
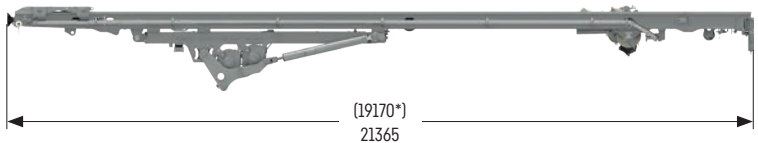
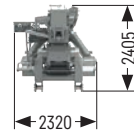
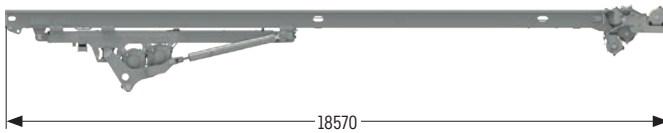

Leader

Weight standard leader	t 16.9
Weight folding leader	t 18.6
Weight drilling version	t 21.3

* leader lower part folded

Options

Concrete supply line	t 0.6
All round platform with railings	t 0.4

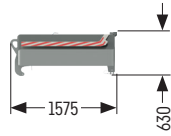
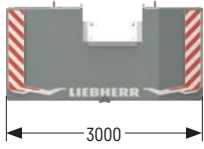

Counterweight

Weight t 8.0

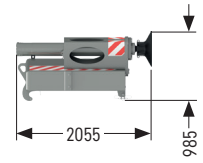
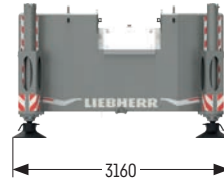

Counterweight with rear support unit

Weight t 8.0

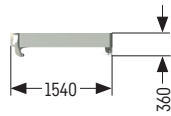
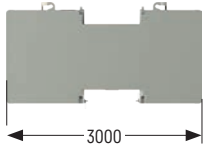

Intermediate slab

Weight t 5.0

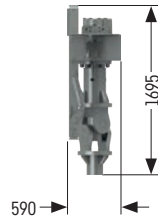
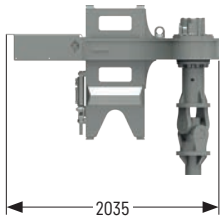

BA 35

Weight t 1.4

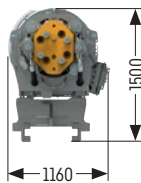
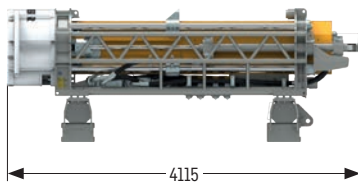

Hammer H 6-6

Weight incl. 6 t drop weight t 9.7

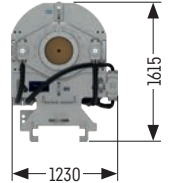
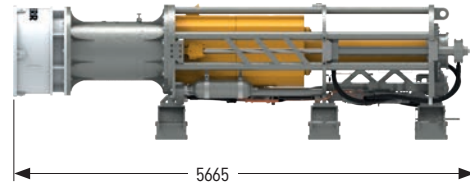

Hammer H 10-100

Weight incl. 10 t drop weight t 16.2

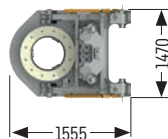
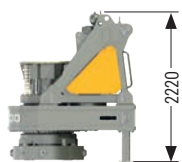

BAT 250

Weight t 6.5

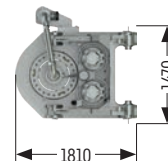
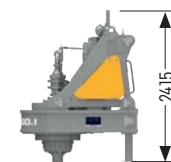

MAT 100.1

Weight t 5.7

Hydraulic hammer H 6 and H 10



Performance data

Hammer type		H 6-3	H 6-4	H 6-5	H 6-6	H 10-75	H10-100
Drop weight	kg	3000	4000	5000	6000	7500	10000
Max. rated energy	kNm	36	48	60	72	90	120
Blow rate	blows/min	50-150	50-150	50-150	40-150	30-100	30-100
Max. pile length*	m	24.4	24.4	24.4	24.4	22.5	22.5
Hammer weight incl. pile helmet and dolly	kg	6700	7700	8700	9700	13700	16200

Various pile helmet sizes up to diameters of 630 mm for the hammer H 6, up to 785 mm for the hammer H 10 and in square design available as standard. Other pile helmet sizes available on request

* For the version without leader upper part the max. pile length is reduced by 5 m.

Pre-drill BA 35

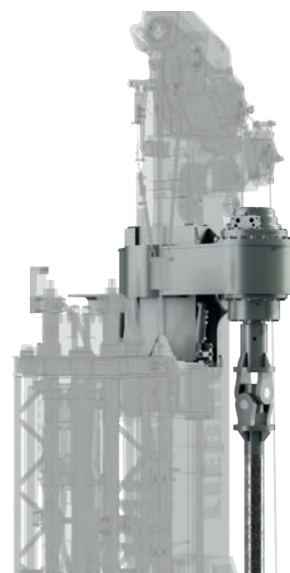
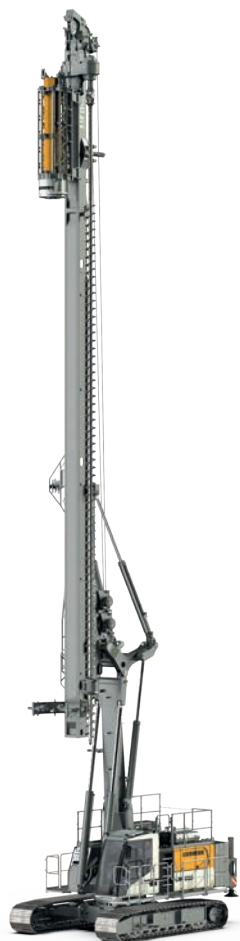

Performance data

Rotary drive - torque	kNm	0 - 35
Rotary drive - speed	rpm	0 - 20
Max. drilling diameter	mm	0 - 350
Max. pile length* H 6/H 10	m	23.4/21.5
Max. drilling depth* H 6/H 10	m	17.4/15.4
Additional crowd force		hammer weight

Other drilling diameters available on request

* For the version without leader upper part the max. drilling depth and max. pile length are reduced by 5 m.

Continuous flight auger drilling

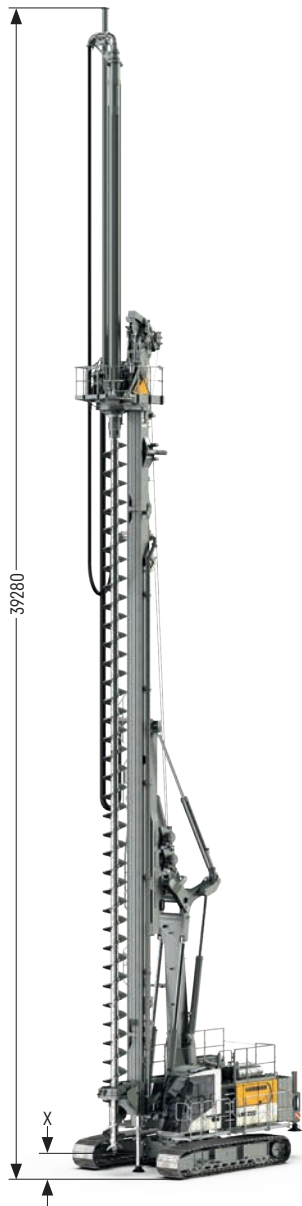

Performance data

Rotary drive - torque	kNm	250
Rotary drive - speed	rpm	58
Max. drilling diameter*	mm	1000
Drilling depth without Kelly extension**	m	24.5
Drilling depth with 10 m Kelly extension**	m	34.5
Max. pull force	kN	400
Max. crowd force	kN	200

Above drilling depths take into account that an auger cleaner is used and the cardan joint has been removed.

Above drilling depths are valid for the use of standard tools and for an X value of 395 mm (see above illustration).

* Other drilling diameters available on request

** For the version without leader upper part the drilling depth is reduced by 5 m.

Full displacement drilling



Performance data

Rotary drive - torque	kNm	250
Rotary drive - speed	rpm	58
Max. drilling diameter*	mm	500
Drilling depth without Kelly extension**	m	25.2
Drilling depth with 10 m Kelly extension**	m	35.2
Max. pull force	kN	400
Max. crowd force	kN	200

Above drilling depths are valid for the use of standard tools and for an X value of 185 mm (see above illustration).

* Other drilling diameters available on request

** For the version without leader upper part the drilling depth is reduced by 5 m.

Soil mixing



Performance data BAT 250

Rotary drive - torque	kNm	250
Rotary drive - speed	rpm	58
Max. mixing diameter*	mm	1500
Mixing depth**	m	24.3
Mixing depth with 10 m Kelly extension**	m	34.3
Max. pull force	kN	400
Max. crowd force	kN	200

Above mixing depths are valid for the use of standard tools and for an X value of 1120 mm for MAT 100.1, and 570 mm for BAT 250 (see above illustration).

* Other mixing diameters available on request

** For the version without leader upper part the mixing depth is reduced by 5 m.



Performance data MAT 100.1

Rotary drive - torque	kNm	95
Rotary drive - speed	rpm	100
Max. mixing diameter*	mm	1000
Mixing depth**	m	24.3
Max. pull force	kN	400
Max. crowd force	kN	200

Down-the-hole drilling



Performance data DHR 110

Rotary drive - torque	kNm	106
Rotary drive - speed	rpm	41
Max. drilling depth	m	25.2
Max. pull force	kN	400
Max. crowd force	kN	200
Leader inclination (forward/backwards/sideways)	°	5.7/18.4/9.5

Elevation mode



By supporting the leader on the ground and extending the rear support cylinders, the carrier machine is elevated. The undercarriage can thus be swivelled on the spot, which makes it easier to move the piling rig in restricted spaces.

Service mode (without attachments)

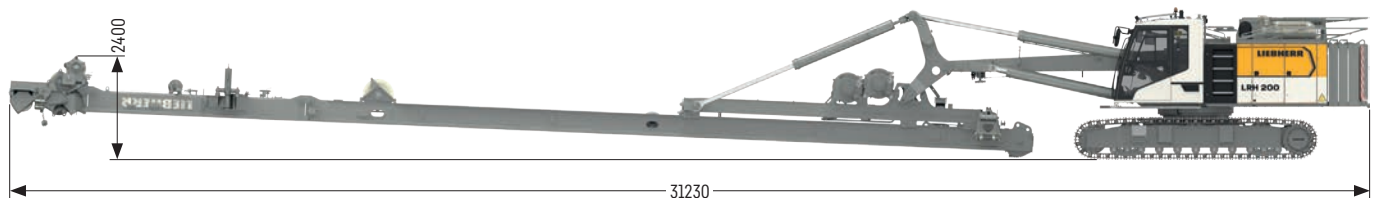

For maintenance and service work on the leader and carrier machine, the leader can be folded forward. In this position the piling rig cannot move or travel.

Digitalization in deep foundation work

As deep foundation expert, Liebherr has created a combination of the most diverse assistance systems and software solutions in order to record and evaluate complex processes and to be able to provide the corresponding evidence.

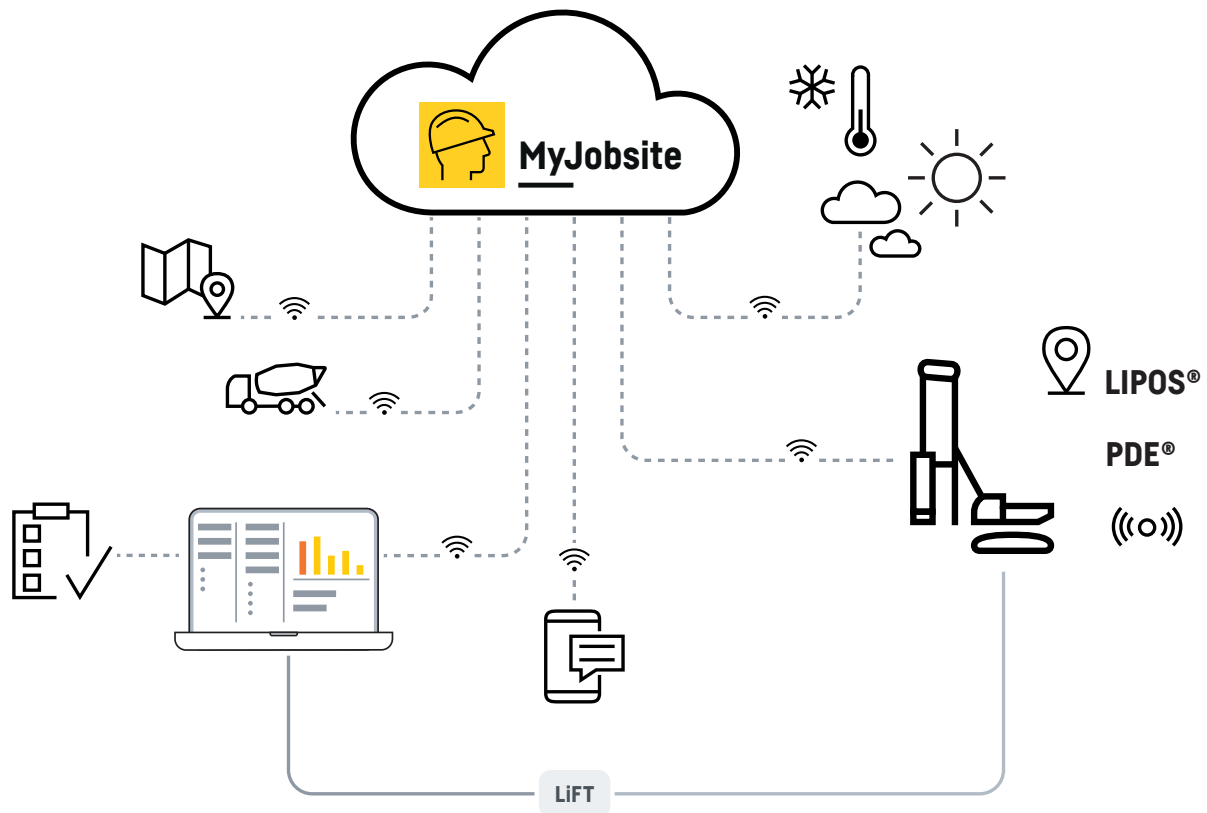

LIPOS - Liebherr Positioning System

Using pre-installed components, LIPOS enables the direct integration of machine control systems from Trimble and Leica. These systems are based on modern DGNSS technology (Differential Global Navigation Satellite System) and so achieve the best possible conditions for a precise and efficient positioning of Liebherr machines and their attachment tools.

PDE

All working processes can be electronically recorded and visualized using the process data recording system PDE. The system is operated and displayed on the PDE touchscreen in the operator's cab. PDE records operating data from the Litronic control system, as well as data from external sensors.

MyJobsite

Using the MyJobsite software solution all relevant process, machine, construction site and positioning data (LIPOS) can be recorded, displayed, analysed, managed

and evaluated in one central location. The collected data can be accessed via a web browser when an internet connection is active.

With the recorded PDE data, such as the driving progress of the pile per blow, the total number of blows, or the impact frequency per minute, a driving protocol is automatically generated as proof of quality directly after completion of a work process. The parameters of the driving protocol can be defined and assigned in advance. Using the templates saves a lot of time when creating the protocols.

MyJobsite is THE tool for quality control and documentation. The deluge of data, which is accrued each day from a wide variety of sources on the jobsite, can be recorded precisely and processed in an informative manner. Unpopular bureaucratic work is kept to a minimum and the amount of time required for it is significantly reduced. At the same time, the quality of administration work is maximised.

Ground Pressure Visualization

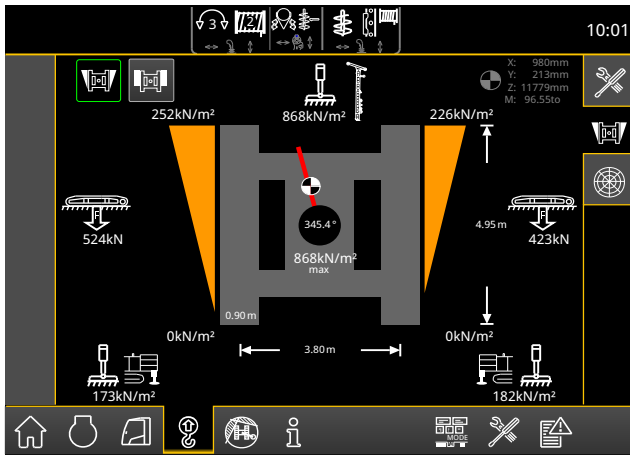

Features:

- The actual ground pressure is calculated in real time
- The maximum admissible ground pressure can be individually predefined
- The utilization is continuously calculated and displayed on the monitor in the operator's cab
- Audible and visual warnings when the predefined values are approached

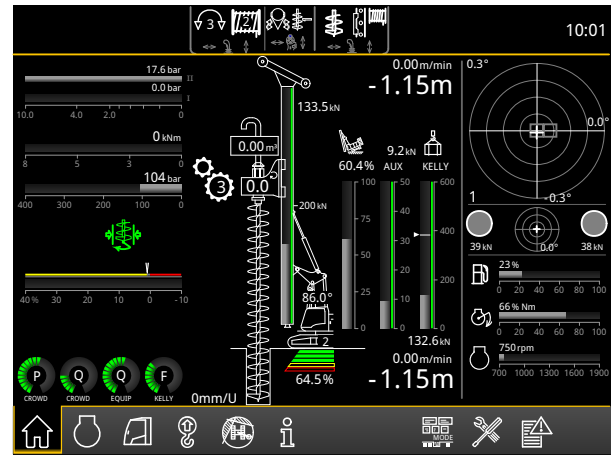

Your benefits:

- Increased safety on the jobsite due to consideration of prevailing ground conditions
- Higher operator comfort thanks to clearly displayed information and warning signals
- Prevention of critical or stressful situations before they occur
- User-friendly and intuitive handling in the operator's cab



Download datasheet



Please contact us.

Liebherr-Werk Nenzing GmbH · Dr. Hans Liebherr Str. 1 · 6710 Nenzing, Austria
Phone +43 50809 41-473 · foundation.equipment@liebherr.com · www.liebherr.com
facebook.com/LiebherrConstruction